

H

Features

- External mounted rodless cylinder
- Rodless cylinder for short overall length
- 1.250 dia. case hardened & ground shafts
- 4 linear ball bearings with long life bearing seals
- Tapped & dowel pin holes in anodized body for ease of mounting
- Tapped & dowel pin holes in anodized end plates for ease of mounting
- Hardened adjustable stopscrews for accurate and repeatable positioning available (see page 146)
- Hydraulic shock absorbers available (see page 139)
- End of stroke sensing switches are available for stop-screws (see page 143-149)

Dimensions

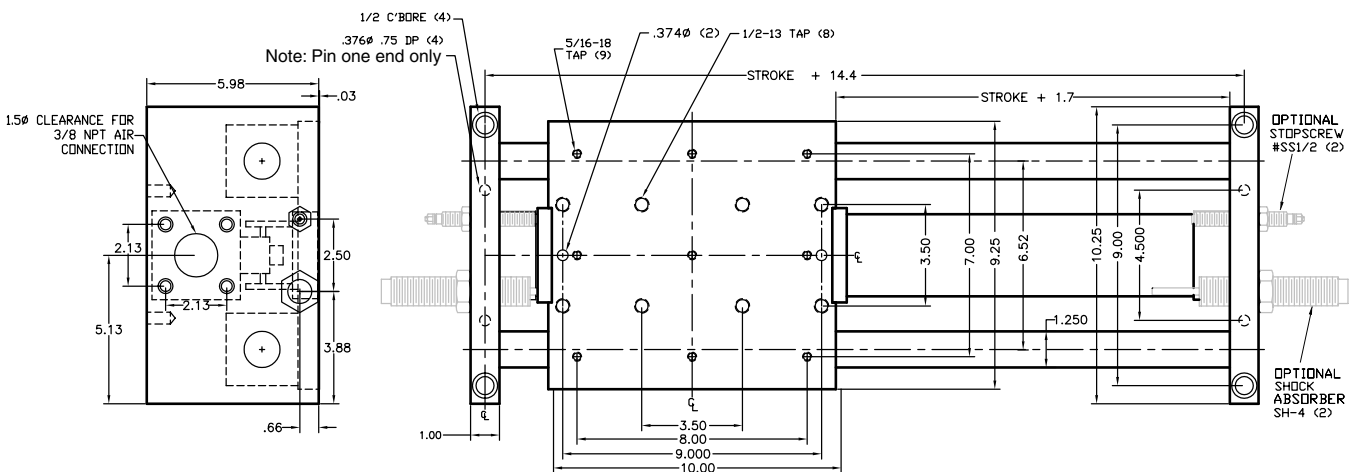

NOTE: Flow controls are recommended for all applications.

TS-5 Table Slide

Technical Data

- Bore = 2"
- Force @ 80 psi = 240 lbs
- Operating medium = compressed air 60-100 psi
- Air connection = 3/8 NPT
- Repeat accuracy = +/-0.0005"
- Life expectancy = >100 million travel inches
- Force diagrams below depict the load and the resultant deflection caused by that force (or torque).

Load Factor (x)

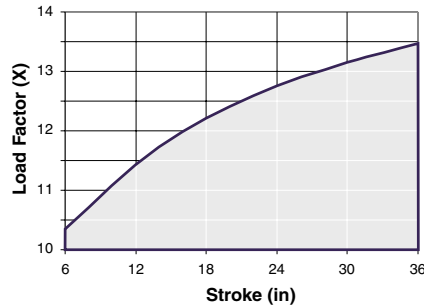

The load factor (X) is used in calculations as a relationship between a load on the ends (F1) versus a load in the center (F3).

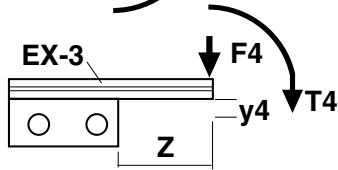
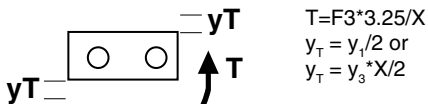
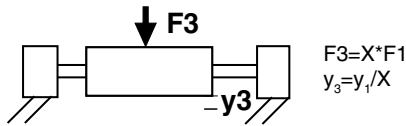

For $T4 = T$;
If $T4 = F4 * (z + 3.25)$ and $T = F3 * 3.25 / X$ then,

$$F4 = F3 * 3.25 / (X * (z + 3.25))$$

F4 is the force that will cause a deflection (y_4) at the block's edge. To determine the deflection at the cantilever end use the following:

$$y_4 = F4 * z^3 / (9.78E+07)$$

F3 Load vs. Travel at set Deflection (y_3) for the TS-5

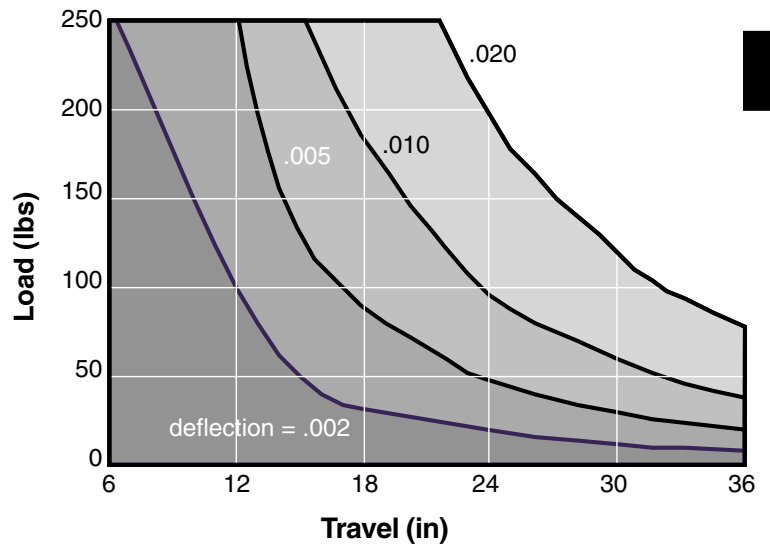

Ordering & Options

TS - 5 - [] - []

STROKE
(1" to 36")

C = Base ES with internal air cushion standard
SS = with 2 Stop Screws
SH = with 2 Shock Absorbers
SB = with both Stopscrews & Shock Absorbers

For end of stroke sensing, see page 143-149

