

# LA-31 Linear Actuator



## Features

- 1 1/2" bore
- 0.750" dia. case hardened & ground shafts
- 4 linear ball bearings and seals
- Cylinders can be rebuilt
- Chrome plated cylinder rods
- Adjustable stopscrews for end of stroke adjustment
- Sensing switches can be used with stopscrews
- Compressed air from 60-100 psi
- 1/8 NPT air connection
- Tapped & dowel pin holes in anodized body for ease of mounting
- End blocks anodized and include tapped & dowel pin holes



I

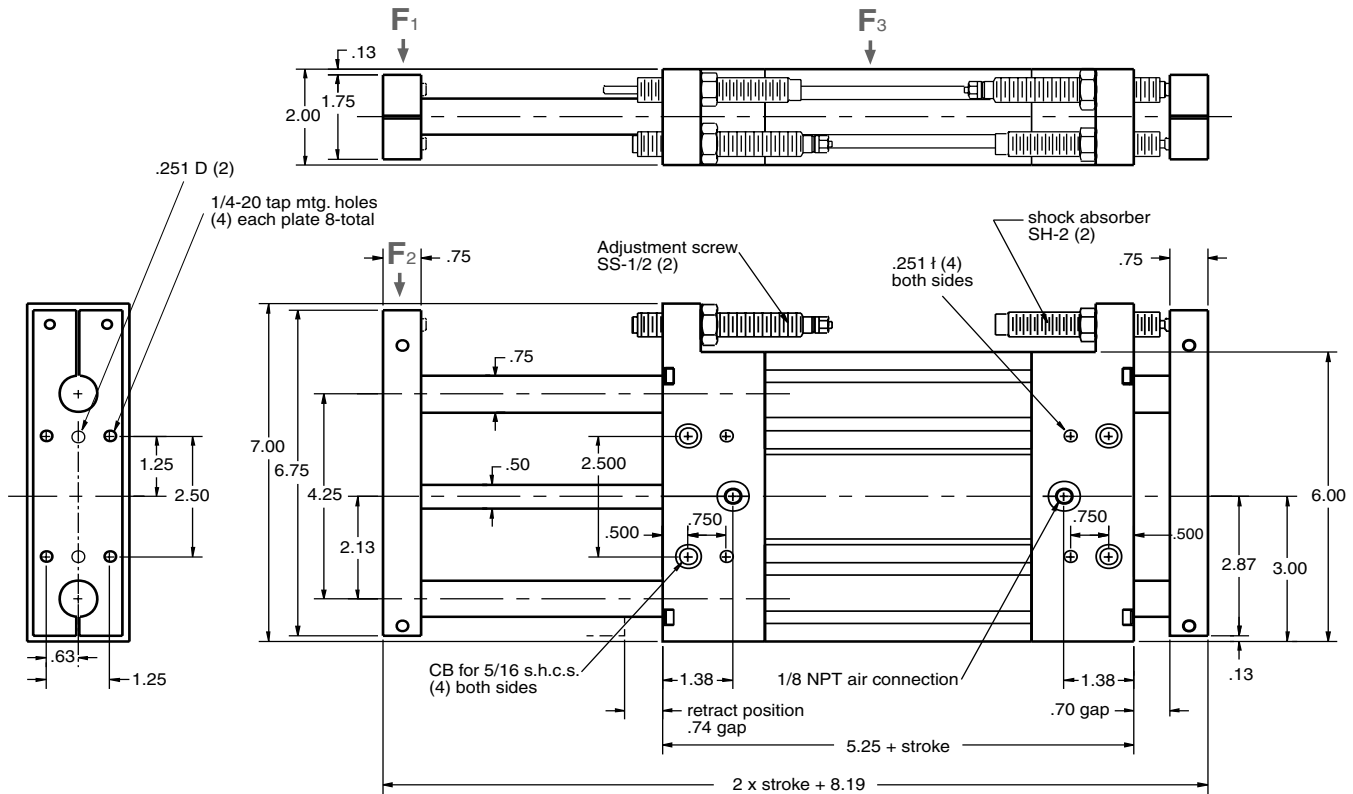

## Ordering

The LA-31 comes in stroke lengths in 1" increments from 1" to 16". Custom stroke lengths are available upon request.

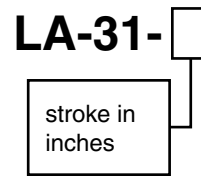

## Technical Data

Force @ 80 psi = 140 lbs  
 Repeat accuracy = +/-0.0005"  
 Life expectancy = >100 million travel inches

Force diagrams below depict the load (F#) and the resultant deflection (y#) caused by that force (or torque T).

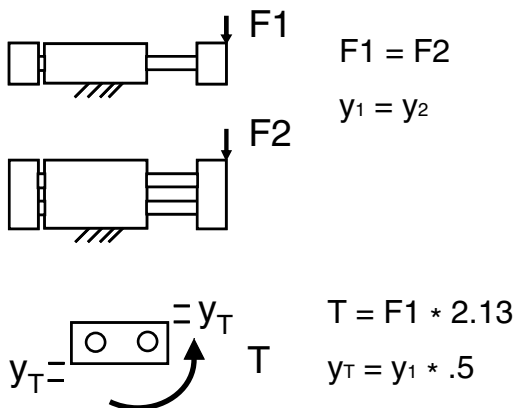

## F1 Load vs. Travel at set Deflections for the LA-31

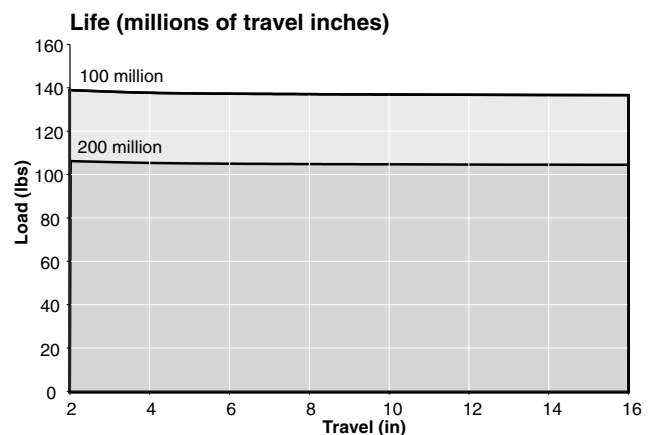
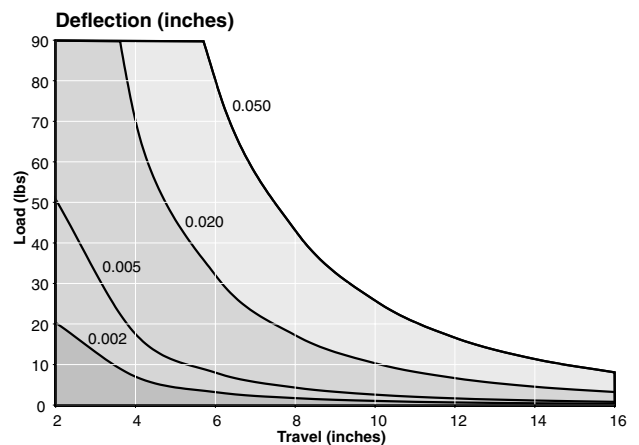

## Options

Sensing switches are available as an option. They are mounted to the stopscrews as seen in the photo to the right. For specifications on sensing please see page 143.

