

Heavy Duty Gripper True Parallel Motion Double Acting



GHD-5

Heavy duty grippers have true parallel motion and are recommended for loads up to 100 lbs.

Tool mounting pads are drilled and tapped for your tooling. Gripper body is anodized aluminum.

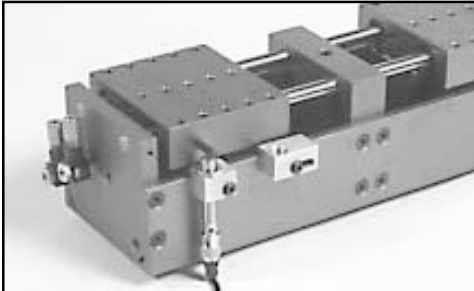
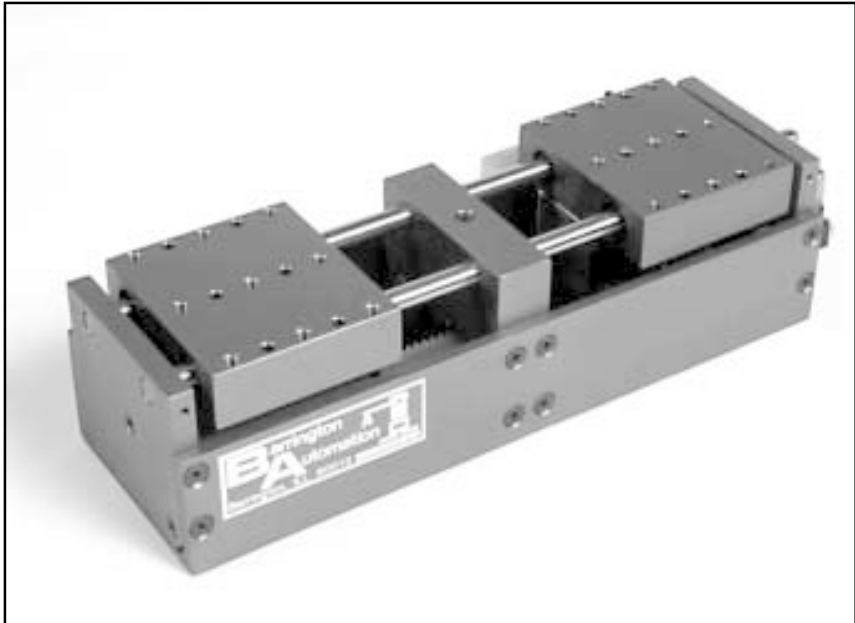

See page 36 for sensing specification

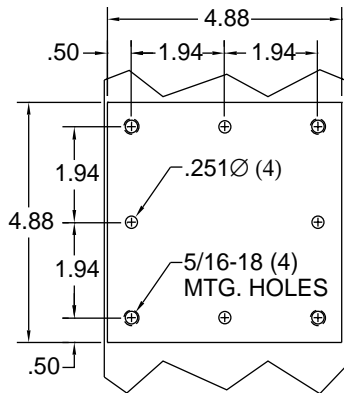

VIEW AA
BOTTOM PLATE MOUNTING HOLES

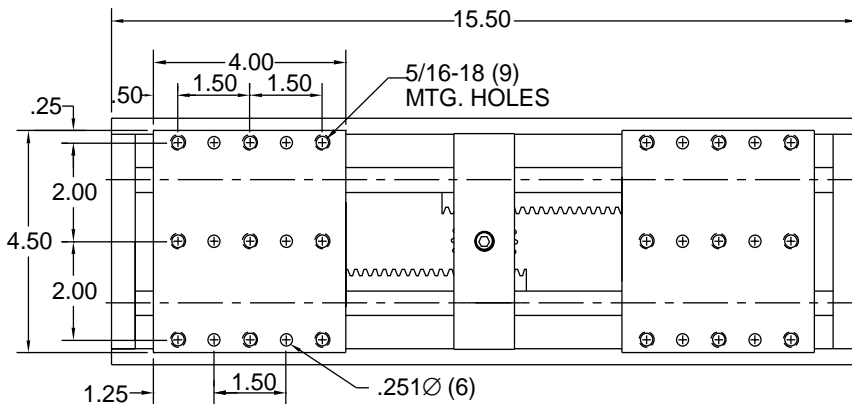
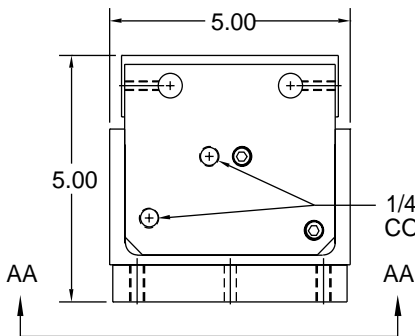

TECHNICAL DATA:

Weight	24 lbs	Gripping Force @ 80 PSI	200 lbs @ F
Max Recommended Load	100 lbs	Operating Pressure	60-100 PSI
		Stroke	4 in