

Features

- Fully assembled Pick & Place unit with all mounting components — ready to install, plumb and run.
- Components come with our stopscrew system for accurate stroke adjustment and optional sensing capabilities. (see page 146)
- Made from our standard proven precision components.
- We will supply a gripper mounting plate or make a custom one for any end-effector.

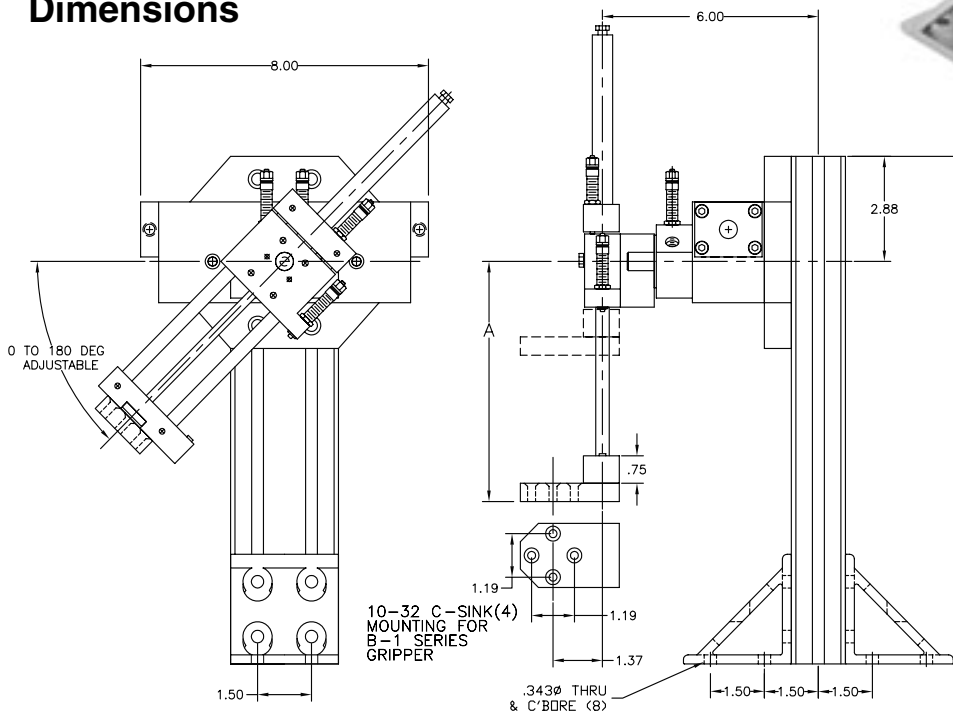

Dimensions



The CMU – RL31 includes MOUNTING stand, RD-3, LA-1, and adapter plates. Grippers and sensors ordered separately. For sensors, see page 143. For grippers, see pages 3-54.

Dimension	LA1-1	LA1-2	LA1-3	LA1-4
A	3.6"	4.6"	5.6"	6.6"

Ordering

Q CMU-RL31 - [] - [] - [] - []

LA-1 Size

- 1 - 1" stroke
- 2 - 2" stroke
- 3 - 3" stroke
- 4 - 4" stroke

EX-2 Height (L)

- 0 - No stand
- 4" to 16" stand

Shock Absorbers

- N - No Shock Absorbers
- S - 2 Shock Absorbers for RD-3

Gripper Hub

- N - No Hub
- 0 - Hub adapter (B-0 series gripper)
- 1 - Hub adapter (B-1 series gripper)

Technical Data

LA -1 = 9/16" BORE

RD-3 = 1-1/4" BORE

AIR CONNECTION = 10-32 (LA-1),
1/8 NPT (RD-3)

AIR PRESSURE = 60 – 110 PSI

RECOMMENDED LOAD = 2 lbs.

For all other technical specifications see Modular Automation catalog.