

Features

- Fully assembled Pick & Place unit with all mounting components—ready to install, plumb and run.
- Components come with our stop-screw system for accurate stroke adjustment and optional sensing capabilities. (see page 146)
- Made from our standard proven precision components.
- We will supply a gripper mounting plate or make a custom one for any end-effector.

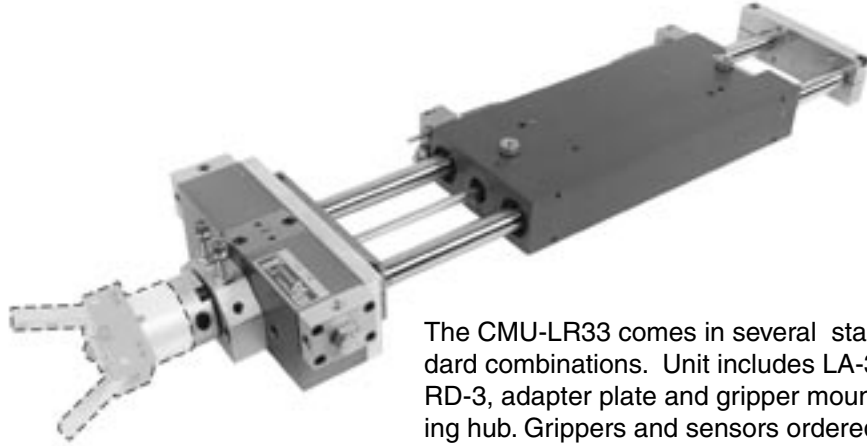

The CMU-LR33 comes in several standard combinations. Unit includes LA-3, RD-3, adapter plate and gripper mounting hub. Grippers and sensors ordered separately. For sensors, see page 143. For grippers, see pages 3-54.

Dimensions

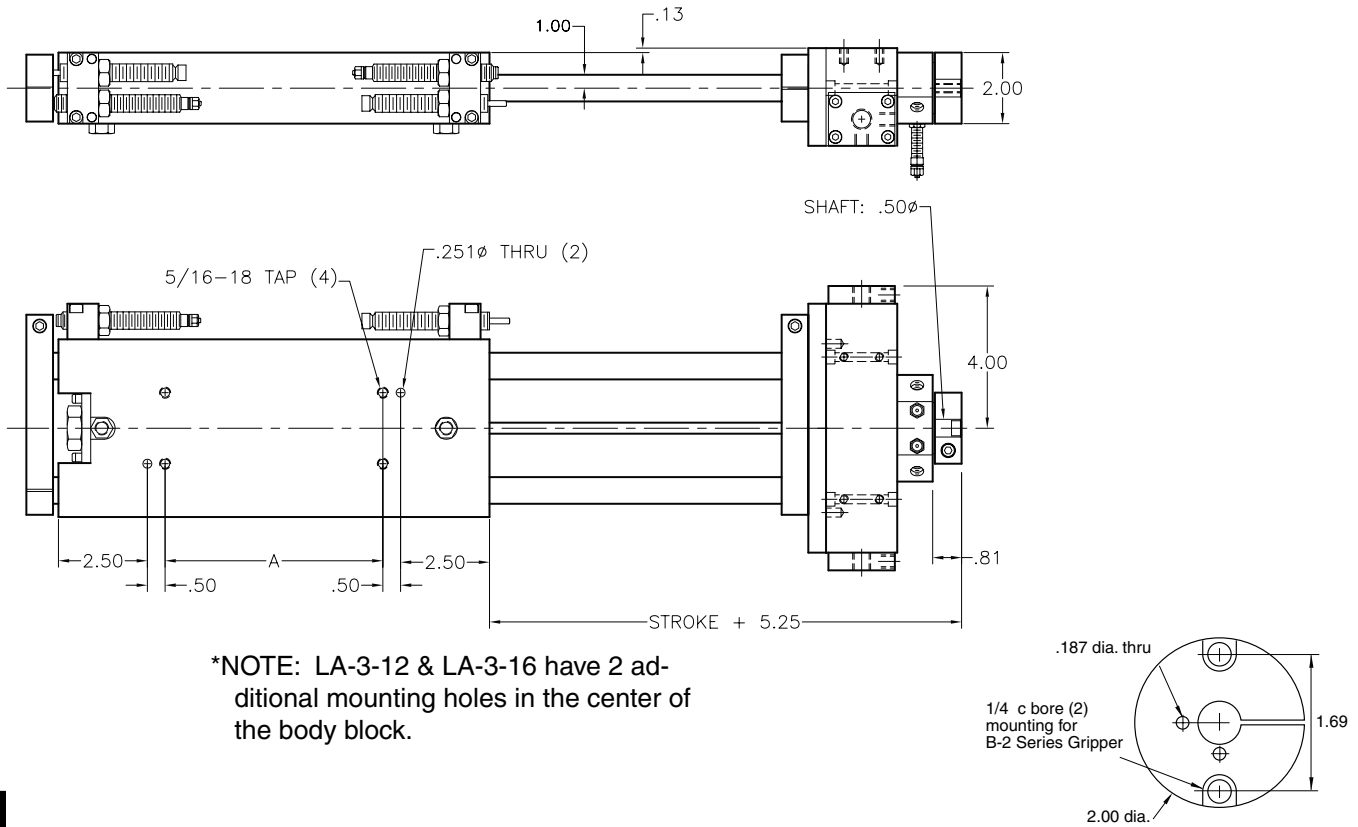

Ordering

CMU-LR33 - [] - []

LA-3 Size
 4 - 4" stroke
 8 - 8" stroke
 12 - 12" stroke
 16 - 16" stroke

Gripper Hub
 N - No Hub
 1 - Hub adapter (B-1 series gripper)
 2 - Hub adapter (B-2 series gripper)

Technical Data

LA -3 = 1-1/8" BORE
 RD-3 = 1-1/4" BORE
 AIR CONNECTION = 1/8 NPT
 AIR PRESSURE = 60 - 110 PSI
 RECOMMENDED LOAD = 12 lbs.