

# CMU-LL21 Combined Motion Linear



## Features

- Fully assembled Pick & Place unit with all mounting components and cable carrier for pneumatic lines—ready to install, plumb and run.
- Components come with our stopscrew system for accurate stroke adjustment and optional sensing capabilities. (see page 146)
- Made from our standard proven precision components.
- We will supply a gripper mounting plate or make a custom one for any end-effector.



## Dimensions

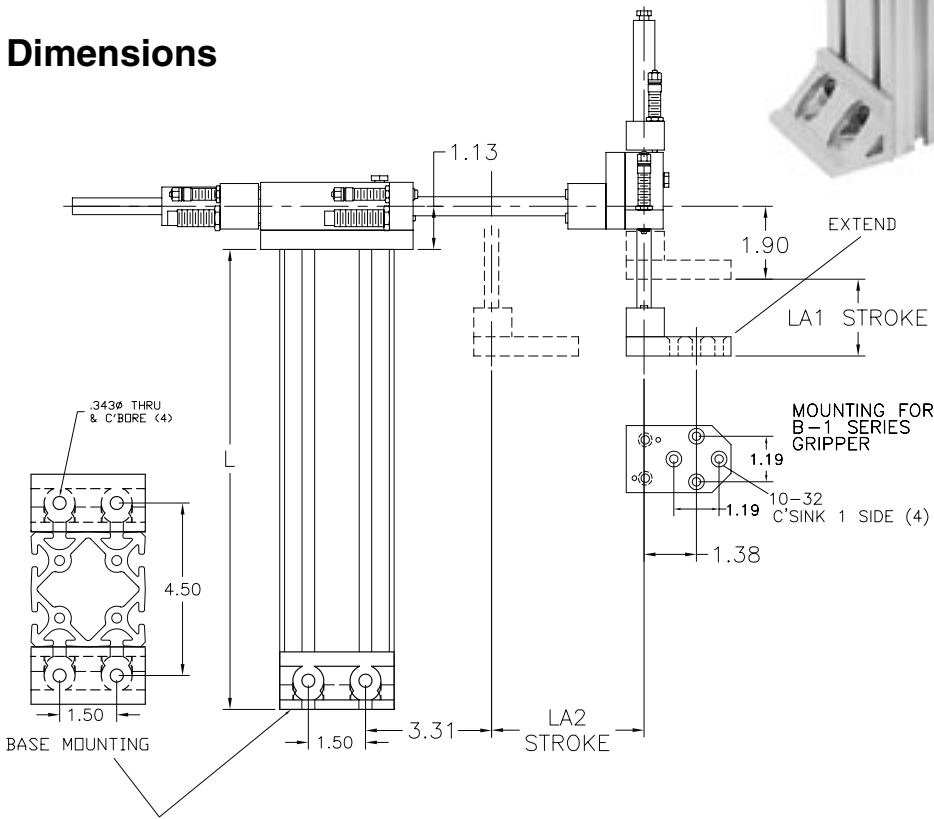

The CMU-LL21 comes in several standard combinations. It includes mounting stand, LA-2, LA-1, adapter plates, and gripper mounting plate. Grippers and sensors ordered separately. For sensors, see page 143. For grippers, see pages 3-54.

## Ordering

**Q** CMU-LL21 - [ ] - [ ] - [ ] - [ ]

LA-2 Size  
 2 - 2" stroke  
 4 - 4" stroke  
 6 - 6" stroke  
 8 - 8" stroke

LA-1 Size  
 1 - 1" stroke  
 2 - 2" stroke  
 3 - 3" stroke  
 4 - 4" stroke

Gripper Adapter  
 N - No plate  
 0 - Hub adaptor (B-0 series gripper)  
 1 - Hub adaptor (B-1 series gripper)

EX-3 Height (L)  
 6 thru 18 inches

## Technical Data

LA -2 = 3/4" BORE  
 LA -1 = 9/16" BORE  
 AIR CONNECTION = 10-32  
 AIR PRESSURE = 60 – 110 PSI  
 RECOMMENDED LOAD = 4 lbs.